

VIEW B

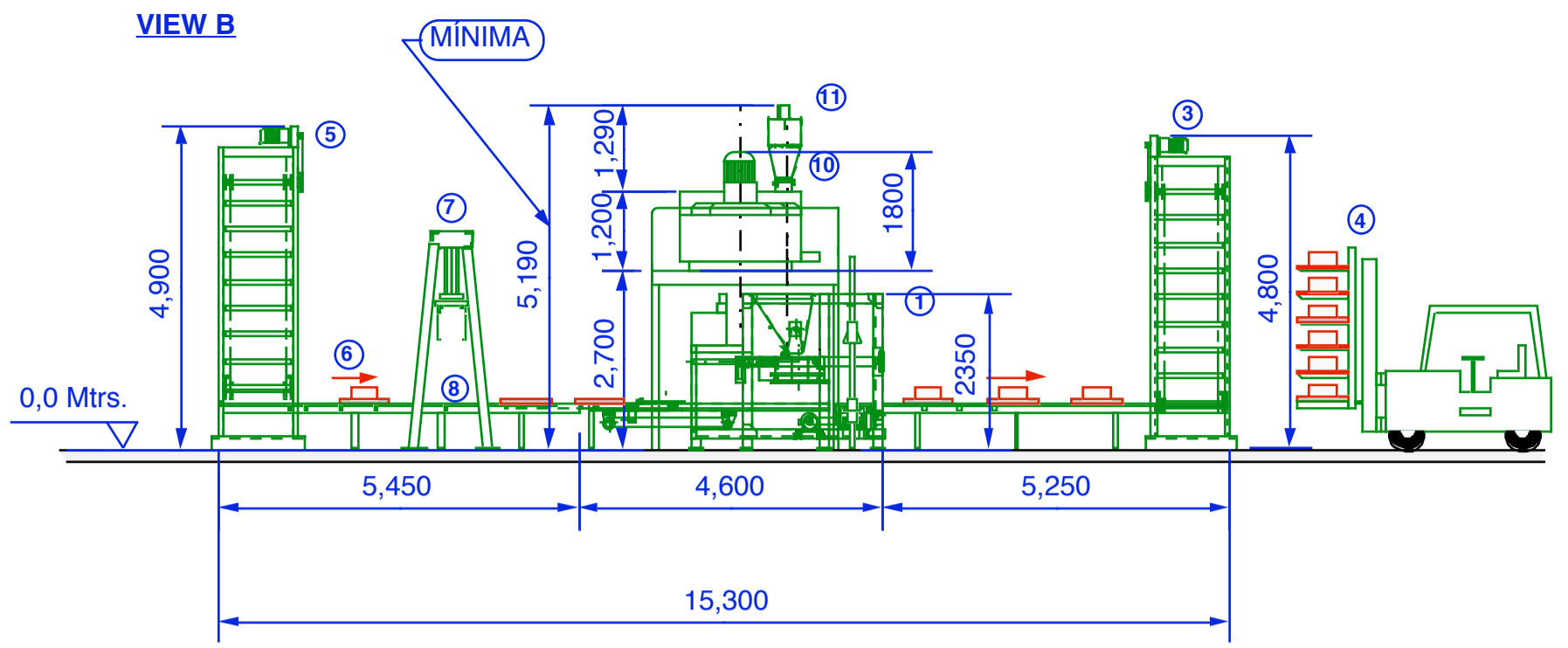

VIEW A

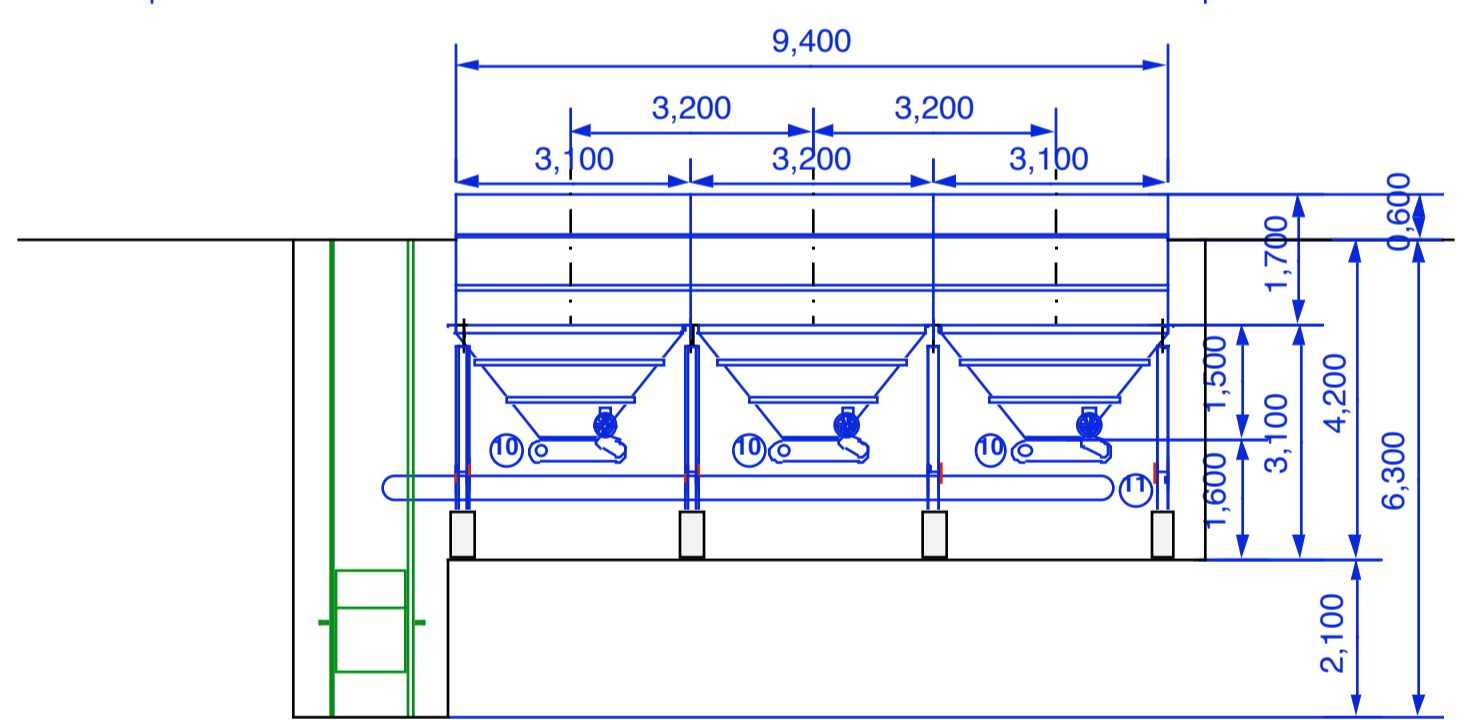
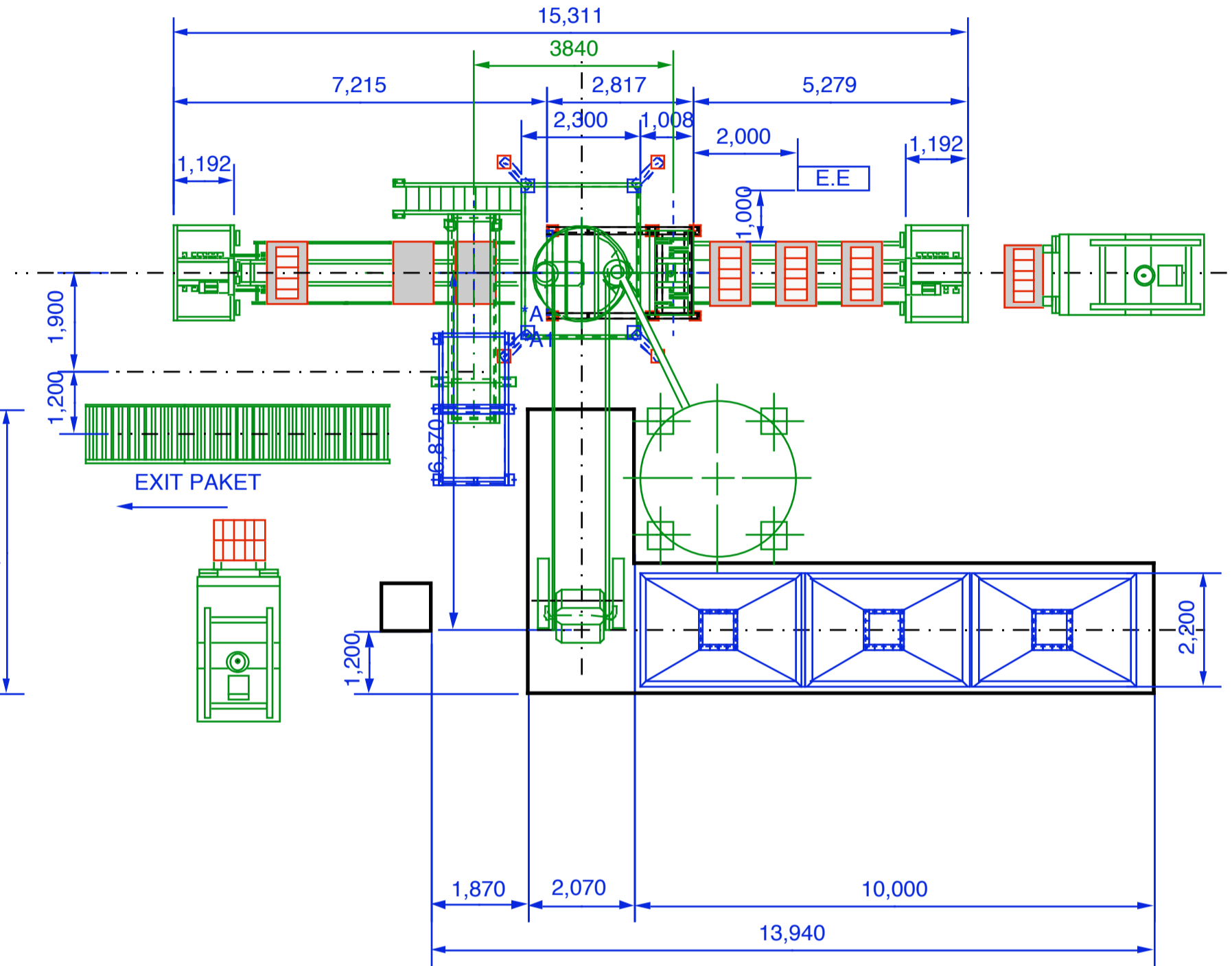
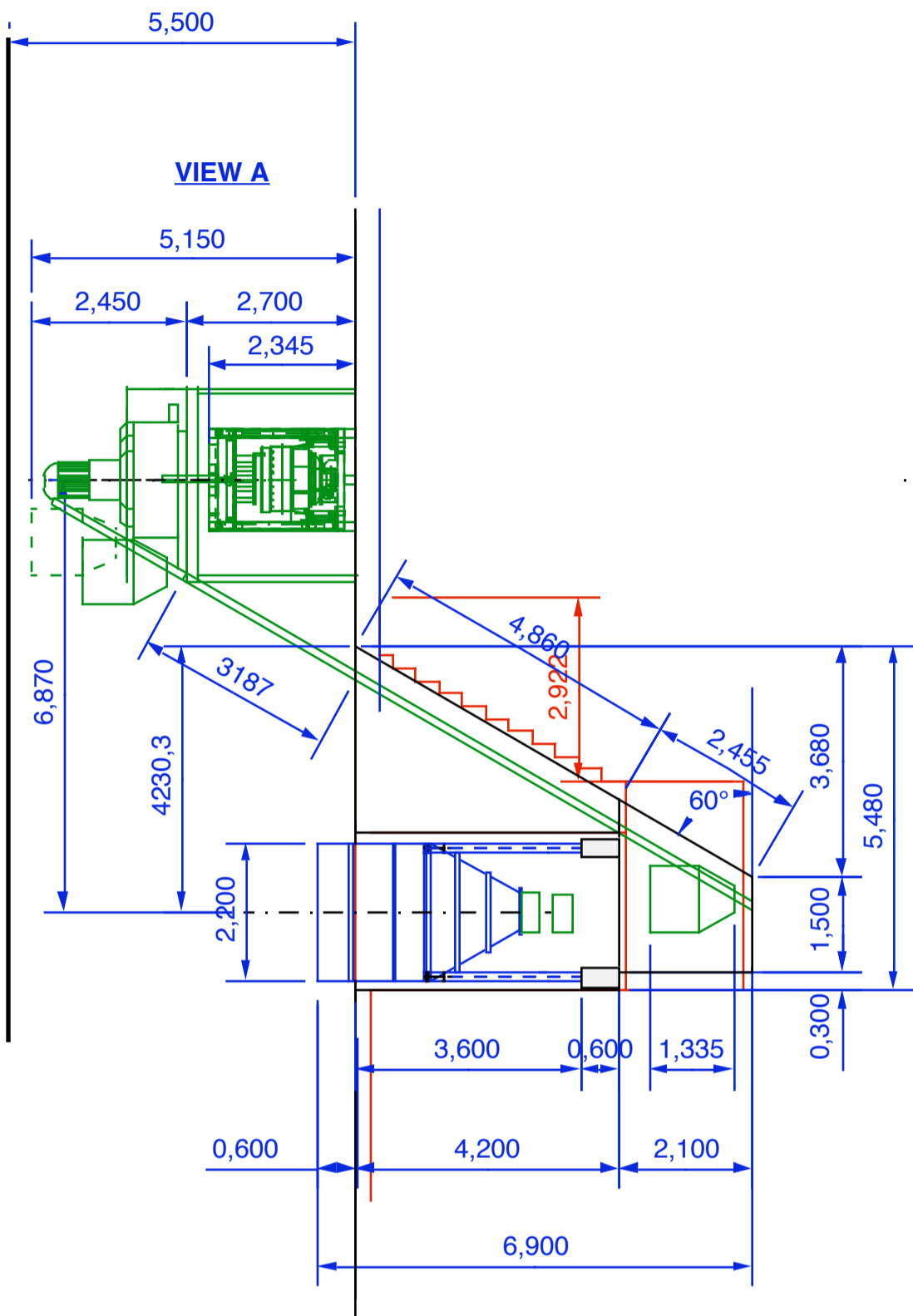

**LEGEND**

- 1. HIDRAULIC CONCRETE PRESS 2010.
- 2. TRAY RECEIVER 133,200.
- 3. ELEVATOR.
- 4. FINGER TO ADAPT TO FORKLIFT
- 5. LOWERING
- 6. TRANSPORT UP TO GRIPPING
- 7. SEMI-AUTOMATIC CUBER.
- 8. TILTING TABLE.
- 9. CONNES 1X1.
- 10. BAND FEEDER.
- 11. TRANSPORT BAND CT10
- 12. PLANETARY MIXER AND SKIP 750.
- 13. CEMENT WEIGHTING SCALE BC200.
- 14. ENDLESS SCREW CEMENT 165X6.
- 15. MIXER SUPPORT 750.
- 16. CEMENT SILO.

1	PLANOL ASOCIAT		NOM	DATA	BLOK-A-BRIK	ROMETA
2	TOL. GENER.	Elaborat:	Sandra Boniquet	07-11-2003		
3	Planol. Substitueix	Aprovat:	Sandra Boniquet	07-11-2003		
4	A	escala	1/100		INSTALLATION	Polg. Industrial - Ronda les Conques 21/26 MOIA Tel: 820 8181 820 8231 Fax: 820 8213 17D-1/2P-222
5					243,00	
6						