

# ROMETA. Layouts 2010

ROMETA. Block making machine

Configuration 1 , 2 , 3

Nov 08

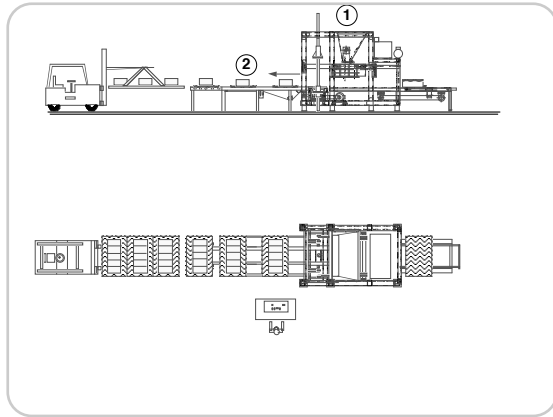

### Configuration 1. Production

1- Block machine 2- Exit table 3- Forklift

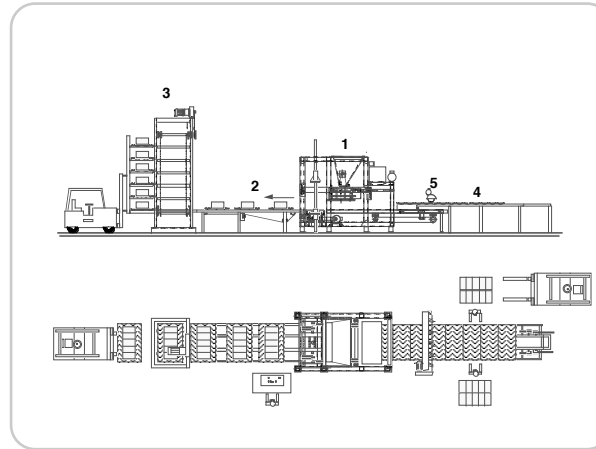

### Configuration 2 . Production

3- Elevator 6 floors 4- Table to feeder machine 5- Pallet brush

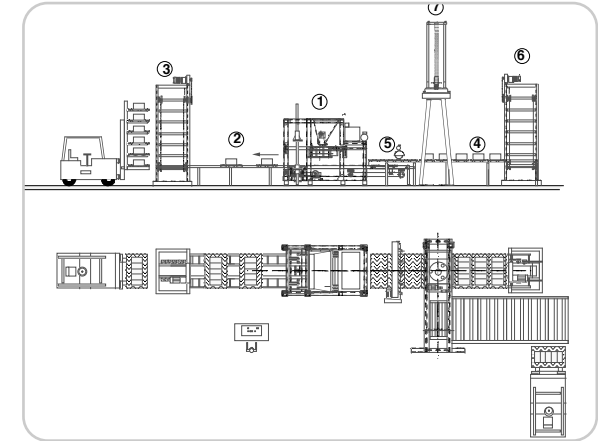

### Configuration 3 Production

6- Lowerator 6 floors 7 - Cubic machine 8- Roller table.

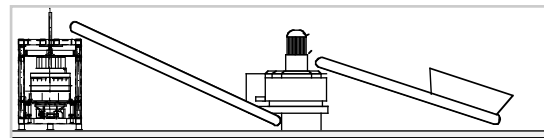

### Configuration 1. Batching plant

Agregates + cement by hand to feeder belt

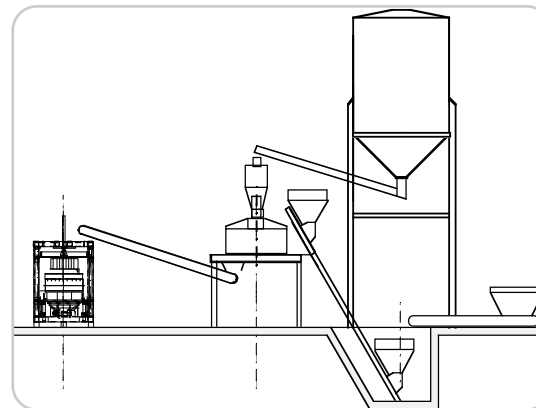

### Configuration 2. Batching plant

Mixer + Skip + Cement balance + Agregates belts . Client : Hoopers

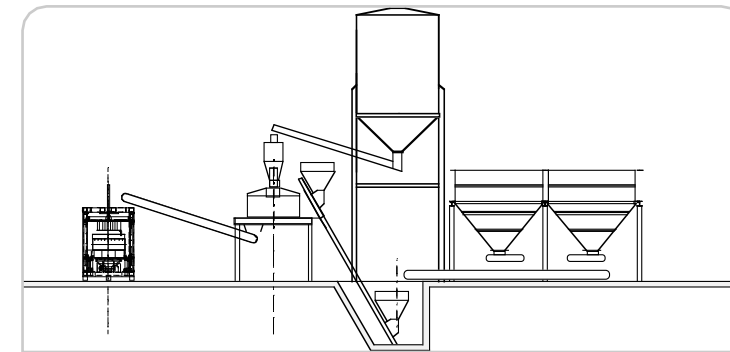

### Configuration 3. Batching plant.

Configuration 2 + Two hoopers complete